

Playground Safety Inspection Tool Kit Instruction Manual

Document Nr.: EIF-20251002_EN

Date: August 26, 2025

Company: Eiffel International Co.



Table of Contents

- 1.Package Contents (Page 3)
- 2.Torso probe, small head and large head Probe (Page 4)
- 3.Fish Probe (Partially Bounded Opening Template) (Page 5)
- 4.Toggle test device (Pages 6-8)
- 5.Finger rod (Page 9-10)
- 6.Chain test rods (Page 11)
- 7.Slide profile gauge(Page 12)
- 8.Ring gauge(Page 13)
- 9.Product spec. & contact info.(Page 14)

1. Package Contents

The inspection kit includes the following items:



1. Large head probe(Probe D)
2. Small head probe(Probe E)
3. Torso probe(Probe C)
4. Fish probe (Partially Bounded Opening Template)
5. Slide profile gauge 50 mm x 100 mm(EN 1176-3)
6. Ring gauge (EN 1176-6)
7. Chain test rods (8.6 mm, 12 mm)
8. Finger rod (8 mm and 25 mm)
9. Toggle test device
10. Shoulder Bag (Available in Black or White, shipped randomly)



2. Torso probe, small head and large head Probe (Ref. Annex D.2.1.2)



(Large head probe)



(Small head probe)



(Torso probe)

Usage Timing and Methods: When using the probes to inspect any openings on playground equipment, pay attention to the direction of the handhold.

•**Physical Passage:** If the torso probe can pass through an opening, it indicates a child's body can also pass through.

•**Safety Risk:** Special attention should be given to openings at higher elevations (e.g., openings around standing platforms). If the torso probe or small head probe can pass through but the large head probe cannot, there is a risk of **head or neck entrapment** (potentially leaving a child suspended in mid-air).

Test Results:

•Pass:

- 1.The torso probe or small head probe cannot pass through the opening.
- 2.The opening allows both the torso probe and the large head probe to pass through.

•**Fail:** The torso probe or small head probe passes through, but the large head probe does not. This opening fails the test.



(Pass)



(Pass)

3. Fish Probe (Ref. Annex D.2.2.2)

Inserting the 'A' portion of the test template into the opening following the centerline of the opening.

Upon inserting the 'A' portion of the test template into the opening, and if there is simultaneous contact between the two corners of the 'A' portion of the test template and the sides making up the boundary of the opening, the opening is considered to PASS the test.

Fail - There is simultaneous contact between the two sides of the 'A' portion of the template and the sides making up the boundary of the opening. The opening should be tested further using the 'B' portion of the template.

Pass - The bottom of the 'A' template is resting on the lower boundary of the opening and there is not simultaneous contact between the two sides of the template and the sides making up the boundary of the opening. Part 'B' test is not required.



Fish Probe

Fail - The size of the components forming the opening allows the 'B' portion of the template to pass into the opening to depth greater than 0.75 in (19.1 mm).

Pass - The size of the components forming the opening does not allow the 'B' portion of the template to fit within the boundaries of the opening.

FIG. A1.7 Exemption for a Thick Surface Condition Using the "B" Portion of the Test Template

4. Toggle test device (Ref. Annex D.3.2)

D.3.2 Procedure

D.3.2.1 Slides

Position the test device perpendicularly in the starting section of the slide, 200 mm from the transition point of the starting section, and at the appropriate lateral location, as shown in Figure D.8. For slides of width greater than 400 mm the test shall be carried out twice with the base positioned at both width extremities of the slide bedway as shown in Figure D.8.

Randomly place the toggle and chain under the action of its own weight to all positions within range, without applying additional force or influence.

NOTE The objective of this test is to replicate the natural motion of a clothing toggle.

In the event that the test device is obstructed, apply a maximum force of 50 N in the direction of the forced movement. If the device is released this position within the equipment passes the test.

Record and report where any entrapment of the toggle or chain occurs.

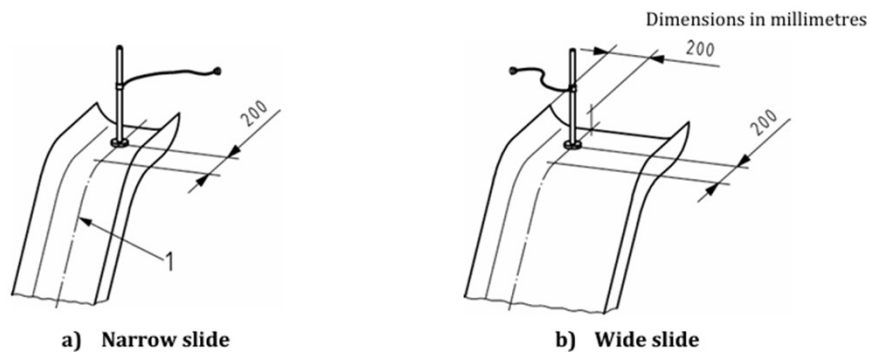

Figure D.8 — Position of the test device on slides



(Continued on next page)

4. Toggle test device (Ref. Annex D.3.2)

D.3.2.2 Fireman's poles

Conduct the test with two different positions of the test device in accordance with a) and b):

a) complete test device (see Figure D.7a)):

Position the test device vertically at the edge of the platform at the point closest to the fireman's pole.

b) toggle/chain:

Detach the toggle/chain from the complete device and position so that it is at a point 1 800 mm above the surface of the adjacent platform or the highest point on the pole, if it extends less than 1 800 mm, (see Figure D.9).

Randomly place the toggle and chain under the action of its own weight to all positions within range, without applying additional force or influence, using the test device as given in a) and then as given in b).

NOTE The objective of this test is to replicate the natural motion of a clothing toggle.

In the event that the test device is obstructed, apply a maximum force of 50 N in the direction of the forced movement. If the device is released, this position within the equipment passes the test.

Repeat the test as given in b) for the entire length of the fireman's pole, down to the point 1 000 mm above ground level.

Record and report where any entrapment of the toggle or chain occurs.

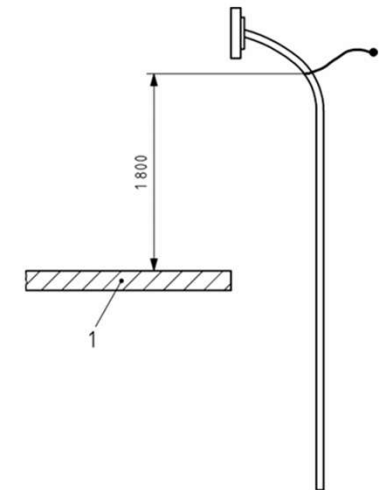

Figure D.9 — Position of the test device on fireman's poles

(Continued on next page)

4. Toggle test device (Ref. Annex D.3.2)

D.3.2.3 Roofs

Detach the toggle, chain and collar from the pole of the complete test device (see D.3.1). Randomly place the toggle and chain under the action of its own weight to all positions at the apex or along the surface of the roof without applying additional force or influence.

If the toggle or the chain resists removal, apply a maximum force of 50 N in the direction of any potential sliding movement of the user. If the toggle and the chain are released, this position within the equipment passes the test.

Record and report where any entrapment of the toggle or chain occurs.

5. Finger rod (Ref. Annex D4.2)

D.4.2 Procedure

Apply the 8 mm diameter finger rod to the minimum cross-section of the opening and rotate it as illustrated in Figure D.11.

Record and report if the rod enters the opening and if it locks in any position when moved through the conical arc shown in Figure D.11.

If the 8 mm diameter finger rod passes through the opening, apply the 25 mm diameter finger rod.

Record and report if the 25 mm diameter finger rod passes through the opening and, if it does, no access shall be given to another finger entrapment site located at less than 100 mm. See Figure D.12.

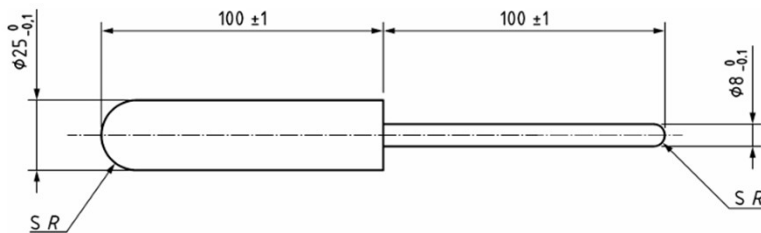

c) Alternative combined finger rod

Key
SR spherical radius

Figure D.10 — Finger rods

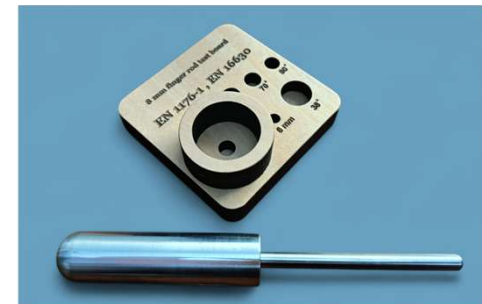

(Continued on next page)

5. Finger rod (Ref. Annex D4.2)

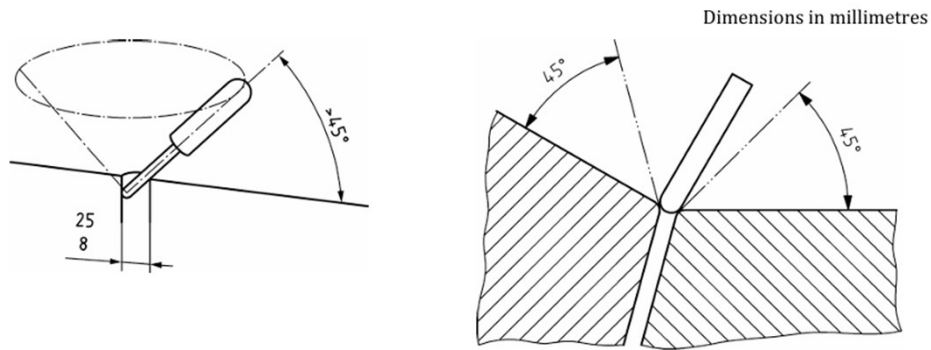
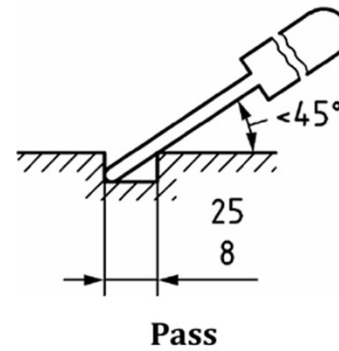
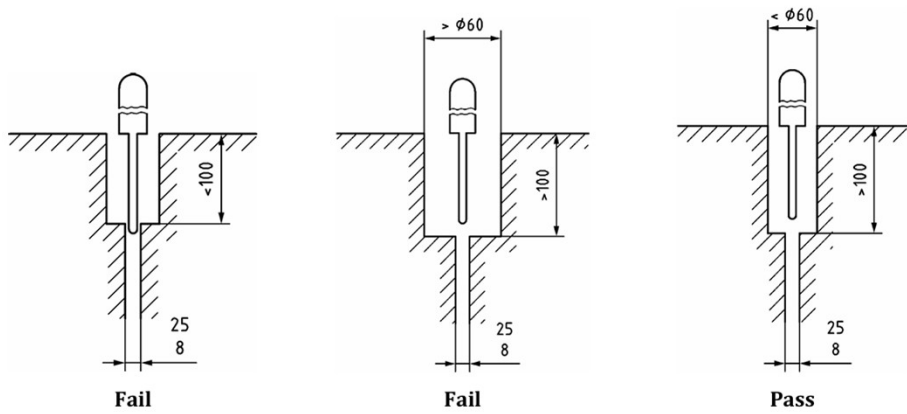
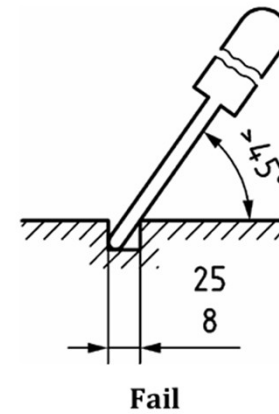

Figure D.11 — Rotation of the 8 mm diameter finger rod



6. Chain test rods (Ref. Annex D5.2)

D.5.2 Procedure

Apply the 8,6 mm diameter rod to the chain opening.

Record and report if the rod enters the opening.

If the 8,6 mm diameter rod enters the opening and the chain opening is part of a connection apply the 12 mm diameter rod.

Record and report if the 12 mm diameter rod passes through the chain opening.

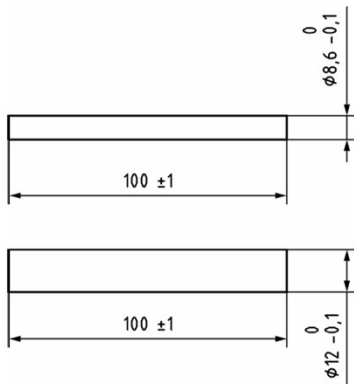

Figure D.13 — Chain test rods



7. Slide profile gauge (Ref. Standard EN 1176-3 Section 4.4.3)

4.4.3 Sides and profile of the slide

In the case of curved profile sided slides, the profile of the sliding section shall be designed in such a way that the short arm of the template (see Figure 5c)) remains horizontal when placed with the long arm perpendicular to the sliding surface at the highest internal point of the inner face of the side (see Figures 5d)) and Figure 5e)).

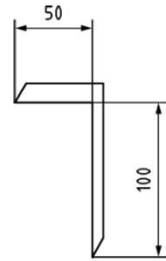

c) Template for determining profile of curved profile sliding section

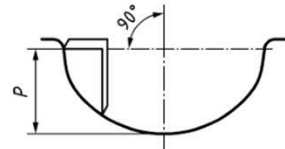

d) Application of template to curved profile sliding — Pass condition

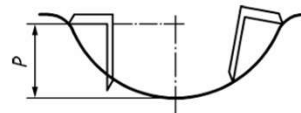

e) Application of template to curved profile sliding section — Fail condition

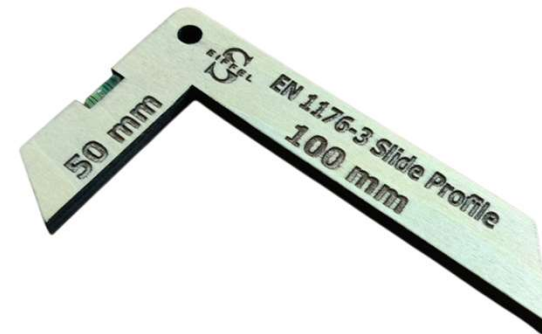

8. Ring gauge (Ref. Standard EN 1176-6 Annex E)

E.2 Procedure

Place the gauge (see Figure E.1) over the projecting end of the hand support or foot rest, as appropriate; apply the gauge only along the centre line of the hand support or foot rest. Determine whether the hand support or foot rest protrudes beyond the outer face of the gauge (see Figure E.2).

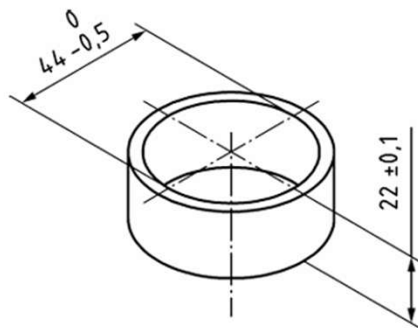
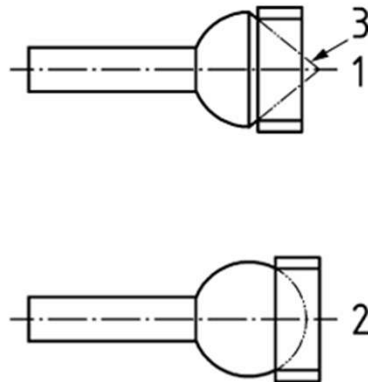

Figure E.1 — Ring gauge





Specifications & Technical Support

- Dimensions:** Compliant with National Standard EN 1176-x (European Standard).
- Material:** Imported lightweight, high-strength basswood, and aluminum alloy.
- Total Weight:** Approximately 550 grams for the full set

2026/5/1 Friday

www.playgroundeiffel.com

Contact us



艾菲爾國際有限公司

莊澤義 Stanley
技術經理 Technical Manager

☎ 0952-701638
✉ stanley6055322@gmail.com
📍 Line ID: stanley6055

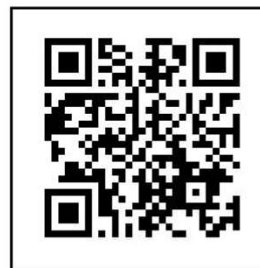
Eiffel Playground.com



Line



WeChat